



Gas Metal Arc Welding (Vertical and Overhead Welding)

Project 1 – Specification and Print

| | |
|-------------------------|-------------|
| Weld Type | Fillet Weld |
| Welding Process | GMAW |
| Position | Vertical |
| Material | 1/4" Steel |
| Joint Type | Tee |
| Backing Option | |
| Backing Material | |

| | |
|---------------------------|------------------------|
| Polarity | DC+ |
| Electrode | ER70s-6 |
| Transfer Mode | Short Circuit Transfer |
| Tungsten Electrode | |
| Shielding Gas | 75% Argon/25% CO2 |
| Flow Rate | 25 cfh |
| Cup Size | |

| Welding Procedure | | | | | | | | | |
|-------------------|----------|---------|-----------------------------|-------------------------------|--------------|---------------------------|-----------------|-------|---------|
| Weld Layers | Pass No. | Process | Filler Metal Classification | Filler Metal Diameter in (mm) | Current Amps | Current Type and Polarity | Wire Feed Speed | Volts | Remarks |
| Weave | Tee | GMAW | ER-70s-6 | .035" | | DC+ | 50 | 7.0 | |
| | | | | | | | | | |
| | | | | | | | | | |





Gas Metal Arc Welding (Vertical and Overhead Welding)

Project 1 – Specification and Print

Heat Treatment:

Preheat Temperature:

Post Heat Temperature:

Interpass Temperature: Quench between passes

Stress Relieving:

Technique: Tee Joint use weave bead vertical up

Additional Notes: Show instructor progress every 30 minutes minimum.





Gas Metal Arc Welding (Vertical and Overhead Welding)

Project 1 – Specification and Print

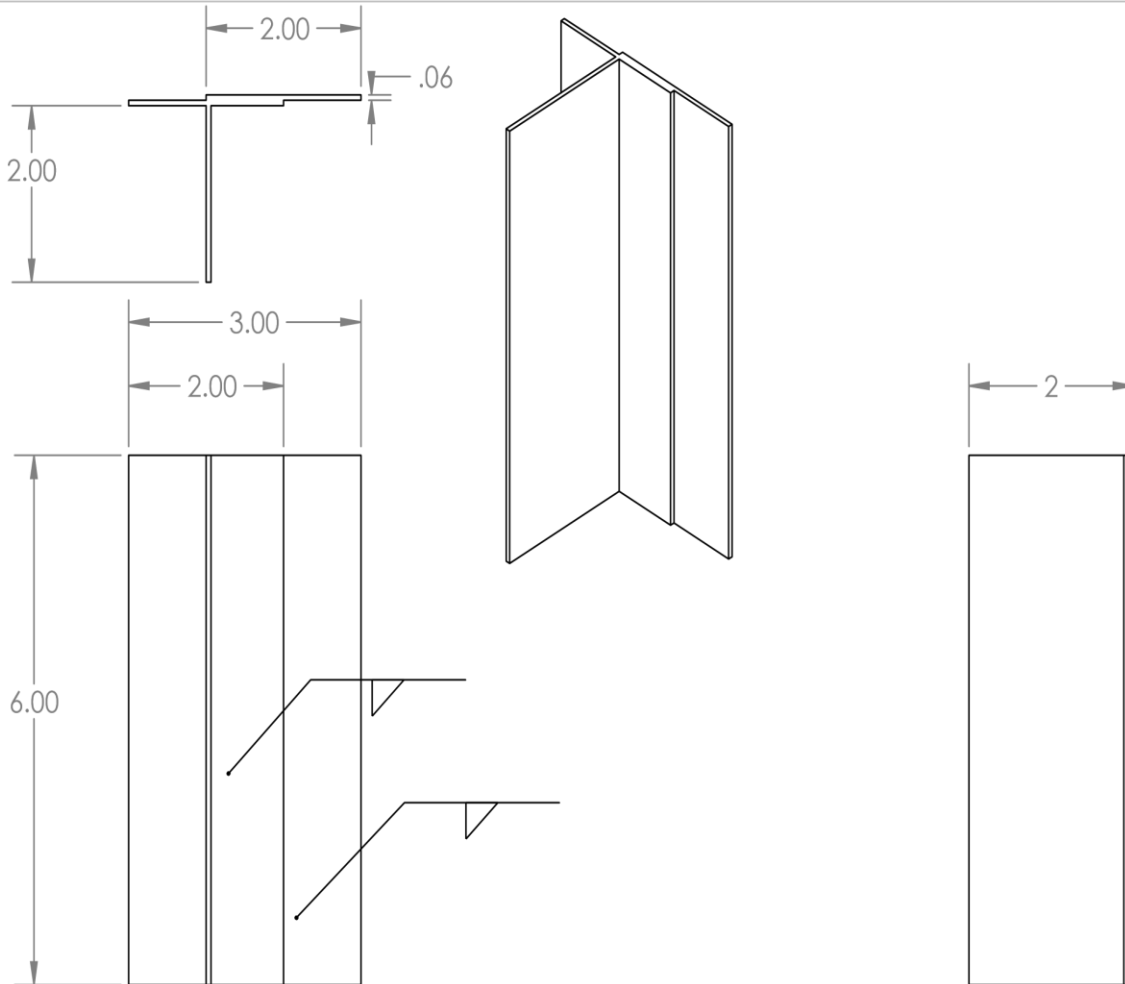

1/8" Steel

PROPRIETARY AND CONFIDENTIAL
 THE INFORMATION CONTAINED IN THIS
 DRAWING IS THE PROPERTY OF
 <INSERT COMPANY NAME HERE>. ANY
 REPRODUCTION OR TRANSMISSION
 WITHOUT THE WRITTEN PERMISSION OF
 <INSERT COMPANY NAME HERE> IS
 PROHIBITED.

**SolidWorks Student Edition.
 For Academic Use Only.**

| | | | | | | |
|-------------|---|--------------------------------------|-----------|------|---------------------------------|--|
| | | UNLESS OTHERWISE SPECIFIED: | NAME | DATE | | |
| | | DIMENSIONS ARE IN INCHES | DRAWN | | TITLE: | |
| | | TOLERANCES: | CHECKED | | CIMWD-131 Project 1 | |
| | | FRACTIONAL ± | ENG APPR. | | | |
| | | ANGULAR: MACH ± BEND ± | MFG APPR. | | | |
| | | TWO PLACE DECIMAL ± | Q.A. | | SIZE DWG. NO. REV | |
| | | THREE PLACE DECIMAL ± | COMMENTS: | | CIMWD 131 pr 1 | |
| | | INTERPRET GEOMETRIC TOLERANCING PER: | | | SCALE: 1:2 WEIGHT: SHEET 1 OF 1 | |
| | | MATERIAL | | | | |
| | | FINISH | | | | |
| 5 | 4 | 3 | 2 | 1 | | |
| APPLICATION | | DO NOT SCALE DRAWING | | | | |





Gas Metal Arc Welding (Vertical and Overhead Welding)

Project 1 – Specification and Print

SAFETY DISCLAIMER:

M-SAMC educational resources are in no way meant to be a substitute for occupational safety and health standards. No guarantee is made to resource thoroughness, statutory or regulatory compliance, and related media may depict situations that are not in compliance with OSHA and other safety requirements. It is the responsibility of educators/employers and their students/employees, or anybody using our resources, to comply fully with all pertinent OSHA, and any other, rules and regulations in any jurisdiction in which they learn/work. M-SAMC will not be liable for any damages or other claims and demands arising out of the use of these educational resources. By using these resources, the user releases the Multi-State Advanced Manufacturing Consortium and participating educational institutions and their respective Boards, individual trustees, employees, contractors, and sub-contractors from any liability for injuries resulting from the use of the educational resources.

DOL DISCLAIMER:

This product was funded by a grant awarded by the U.S. Department of Labor's Employment and Training Administration. The product was created by the grantee and does not necessarily reflect the official position of the U.S. Department of Labor. The Department of Labor makes no guarantees, warranties, or assurances of any kind, express or implied, with respect to such information, including any information on linked sites and including, but not limited to, accuracy of the information or its completeness, timeliness, usefulness, adequacy, continued availability, or ownership.

RELEVANCY REMINDER:

M-SAMC resources reflect a shared understanding of grant partners at the time of development. In keeping with our industry and college partner requirements, our products are continuously improved. Updated versions of our work can be found here: <http://www.msamc.org/resources.html>.

